

User manual 



Ride like the Dutch |

ROYAL DUTCH
Gazelle



Congratulations on your new Gazelle bike!

With your new Gazelle, you are assured of thousands of miles of relaxed and carefree cycling pleasure. Your comfort and safety have been at the forefront for Gazelle, ever since the first bicycle Gazelle manufactured back in 1892. Gazelle was the first cycle brand in the Netherlands to have been awarded the ISO 9001-2000 certificate for its quality systems.

Your Gazelle bike has of course been designed and manufactured with the greatest possible care, using high-grade and durable materials. Accordingly, Gazelle offers you a long warranty. You will find our warranty terms and conditions in the Safety & Warranty manual (**see www.gazellebikes.co.uk/service-and-warranty/manuals**).

In order to be able to derive optimum enjoyment from your new bike, it is important to maintain it properly and have it checked regularly by your Gazelle specialist. In this booklet you will read how best to do this, and how you can carry out any minor repairs yourself. You will also find all the information you need to set up your bike exactly in line with your needs and wishes.

We therefore advise you to read through this user manual attentively and keep it safely. Your Gazelle specialist is always ready to advise and assist you.

We wish you many miles of cycling enjoyment!

Royal Dutch Gazelle

Table of contents

General information	5	9. Bottom bracket, cranks and pedals	32
1. Handlebar	7	9.1 Maintenance	32
1.1 Adjustment	7	9.2 Repairs	32
1.2 Maintenance	9	10. Bike stand	33
1.3 Safety & repairs	10	11. Wheels	34
2. Handlebar grips	10	11.1 Adjustment	34
3. Front fork & head tube suspension	11	11.2 Repairs	34
3.1 Set-up	11	11.3 Removing a wheel	34
3.2 Maintenance	12	12. Tyres	37
4. Lighting	13	12.1 Maintenance	37
4.1 Controls	13	12.2 Repairs	37
4.2 Repairs	15	13. Saddle	40
5. Brakes	18	14. Frame	42
5.1 Adjustment	18	15. E-bikes	43
5.2 Maintenance and repairs	18	16. Child seats	44
6. Gears	22	17. Transporting your bike by car	44
6.1 Internal hub gear adjustment	22	18. Accessories	45
6.2 Internal hub gear maintenance	24	19. Theft prevention	45
6.3 Derailleur gear controls	24	20. Component designations	46
6.4 Derailleur gear adjustment	24	21. Tables	48
6.5 Derailleur gear maintenance	25	21.1 Tightening torques	48
7. Chain and belt drive	27	21.2 Distance travelled per revolution	48
7.1 Adjustment: chain tension	27	21.3 NuVinci gear range	49
7.2 Maintenance	27	22. Contact details	50
7.3 Repairs	28	Finally	50
7.4 Belt drive adjustment	28	Disclaimer	50
7.5 Belt drive maintenance	29		
8. Chain case	30		

General information

It is advisable to have your bike checked regularly by your Gazelle specialist. We advise having the first service carried out on your bike around six weeks and no later than three months after starting to use it. Thereafter, it is desirable to take the bike to your Gazelle specialist once a year for a routine service. This will cover aspects such as ensuring spoke tension is still correct and checking whether there is any play in the hubs, the bottom bracket or the headset.

If you detect any play while riding your bike you are best going straight to your Gazelle specialist. If you carry on cycling too long with defects, this can only make the problems worse and ultimately cause damage. By having your bike adjusted and checked on a regular basis you will avoid expensive repair charges.

We do of course accept that you might like to look after maintenance and minor repairs yourself. This user manual explains how to maintain, adjust and repair your bike. If you can't manage it yourself or are in doubt as to the correct procedures, please make your way to your Gazelle specialist. Maintenance, repairs or adjustments carried out incorrectly can result in defects.

NB

- Bolts, screws and nuts must be tightened to the specified torques. Overtightening them can lead to cracks and failures! You will find a listing of all specified tightening torques in chapter 21, table 1.
- NEVER use a pressure washer to clean your bike. If you do so, it can force grease and/or oil out of components which could result in corrosion or serious damage.
- A particular type of bike will not be suitable for every type of terrain. Bikes are not intended for extreme loads such as those encountered when jumping or riding over steps. Trekking bikes can be used on paved roads and in traffic. They are also suitable for use gentle terrain, such as off-road cycle trails. Urban, touring and children's bikes can be used in traffic and on paved roads. Neither the manufacturer nor the Gazelle specialist can be held liable for improper use of the bike, especially a failure to comply with safety guidelines, and any loss or damage arising from such use.
- Take care to ensure that loose clothing, scarves, laces, etc., do not get trapped in moving parts such as spokes or pedals.
- Like any mechanical system, a bike is subject to wear and tear. Wear and tear can affect the various components in different ways. More intensive use will shorten the lifespan of certain components.
- It is advisable to use a bike helmet for added safety. Observe the national rules and standards for use of helmets in all cases.
- Always comply with local and national traffic rules which apply in the country where you will be using the bike.

1. Handlebar

1.1 Adjustment

The height of the handlebar determines the pressure on your hands and your back posture, among other things, and therefore has a substantial impact on your ride comfort. Gazelle bikes are fitted with different types of handlebars. Of course they are all height-adjustable.

NB

- If you adjust the handlebar height, take care to ensure that the MAX safety marking on the stem is not visible (see fig. 1). If it is visible, it means that the handlebar is set too high. With the Switch stem, the steerer tube needs to extend at least to the min/insert mark.
- Avoid accidents, do not adjust the stem while riding!

Switch and Switch SL

The Switch stem height can be adjusted in two ways: by tilting the handlebar, or by raising the stem itself.

Do you want to adjust your stem height? On the regular Switch (figs. 2 to 3), you unscrew bolt (C) using a 6 mm Allen key. This bolt is exposed when you lift the lever. To adjust the height of the Switch SL (fig. 4) stem, you unscrew bolts (D) using a 5 mm Allen key. You can now adjust the stem. Once you have done so, tighten bolts (D) again.

The easier method is using the tilt system: you don't need any tools for this. First, pull the safety slide (fig. 2, A) on top of the handlebar downwards. Then pull the entire lever (fig. 3, B) upwards. You can now tilt the handlebar to the desired height. The handlebar will be locked as soon as you push the lever back down again.

Magix and Smica (adjustable)

With Magix and Smica stems (see fig. 5) the stem is clamped directly onto the steerer tube (this tube is the upper part of the front fork). You adjust the handlebar height by means of bolts (A). Unscrewing bolt (B) enables the angle of the front assembly and hence the handlebar height to be adjusted.

Finally, you can tilt the handlebar tube itself. You can do this by unscrewing bolt (C). If you have a Smica stem, you



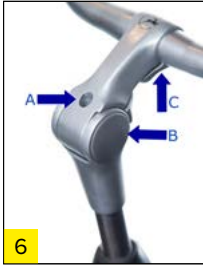

can unscrew the bolts using a 5 mm Allen key; you will need a 6 mm key for the Magix.

Shuttle and New Shuttle

In order to adjust the height of the Shuttle or New Shuttle stem (see fig. 6), you need to remove the cap from the stem first. You can then twist the front assembly so as to expose bolt (A). You can unscrew it with a long Allen key (6 mm), whereupon you can adjust the handlebar to the desired height. Re-tighten the bolt firmly once you have finished. You adjust the position of the front assembly with bolt (B) and the handlebar tube with bolt (C). You need to use a 6 mm Allen key for this as well.



CQS-JM3358-2 stem

You can adjust the height of the stem using the bolt (fig. 7, A) at the top of it. You unscrew bolt (B) to adjust the front assembly. If you want to tilt the handlebar itself, you do so using bolt (C). You need to use a 6 mm Allen key for all the bolts.

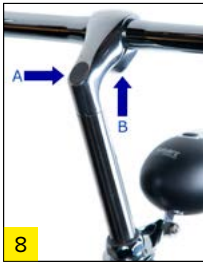

Fixed stem

To adjust the height of the stem itself, you unscrew bolt (A) by a couple of turns using a 6 mm Allen key (see figs. 8 and 9). You will then need to give it the bolt couple of taps with a (rubber) hammer. You will now be able to set the handlebar to the desired height by turning it back and forth. Re-tighten the bolt firmly once you have finished. You can adjust the position of the handlebar tube using clamping bolt (B).

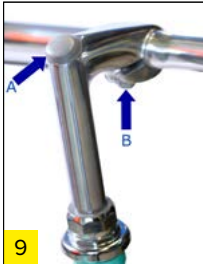

Ultimate Speed handlebar stem (figure 9.1)

You can adjust the handlebars to suit your preference. Your handlebar setting will affect your seating posture. For a sporty posture (leaning forward), you need to set the handlebars further away from you and lower down. For a more comfortable posture (sitting more upright), you need to set the handlebars higher up and closer to you. Both the handlebar stem angle and the rotation of the handlebars can be adjusted.



To adjust the handlebar stem

1. Slacken the locking mechanism on the underside of the handlebar stem with a 4 mm Allen key (B) and unscrew

the socket-head cap bolt on the side of the handlebar stem with a 5 mm Allen key **(A)**

2. Adjust the handlebar stem as desired. Upwards to sit rather more upright and downwards for a sportier posture.
3. Tighten the handlebar stem firmly with a 5 mm Allen key (15-18 Nm) **(A)** while holding it in the desired position. Next, tighten the locking mechanism with a 4 mm Allen key (6-8 Nm) **(B)**.

To adjust the angle of the handlebars

1. Slacken the 4 bolts with a 4 mm Allen key **(C)**
2. Rotate the handlebar to the desired angle, make sure you keep the handlebar tube centred in the handlebar stem while doing so.
3. Next, tighten bolts again with a 4 mm Allen key (5-6 Nm) **(C)**

Head lock

Various Gazelle models feature a head lock. This prevents the handlebar from swinging right round. You activate the head lock by twisting the black ring counterclockwise (see **fig. 10**). The arrows and the padlock icons on the aluminium ring indicate the direction of rotation. You will see a red strip when the head is locked. Should you accidentally set off with the head still locked, you will still be able to turn the handlebar to avoid any accidents. You will hear a ratcheting sound, intended to draw your attention to the fact that the head lock is still engaged. You release the head lock by twisting the black ring clockwise, after which the bike can be steered normally.



1.2 Maintenance

The handlebar stem and the headset require lubrication every so often. If you notice that steering is stiff, creaks or does not operate correctly in some other way, then it may need lubrication. You can go to your Gazelle specialist for this.

1.3 Safety & repairs

After a long period of use, the headset may get a little loose. If this is the case you will need to visit your Gazelle specialist, who has the knowledge and tools available to remedy the problem at once. Should you be unlucky enough to have a fall and bend or damage the handlebar as a result, it must be replaced. Attempting to bend the handlebar back into shape may cause it to break. Deep scratches in aluminium handlebars risk developing into fractures. This also requires the handlebar to be replaced.

2. Handlebar grips

To prevent handlebar grips from working loose, Gazelle has developed handlebar grips that can be secured with a small bolt (**see figs. 11 and 12**).

If you would like to rotate your grips a little around the handlebars you will need to unscrew bolt (**A**) slightly first using a 4 mm Allen key. Once you have set it to the desired position, you need to secure the handlebar grip again by tightening the small bolt.

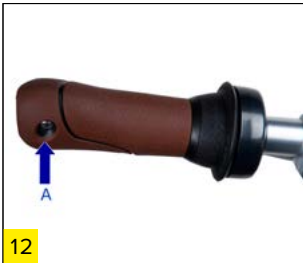

3. Front fork & head tube suspension

Some Gazelle bikes are fitted with a suspension front fork. There are two types of suspension: front fork suspension and internal headset suspension. You can read how to set up both of them here. With front fork suspension, the suspension mechanism is located in the front fork legs; if you have internal headset suspension, then the suspension mechanism is built into the steerer tube.

3.1 Set-up

Front fork suspension

You set the stiffness of the front fork suspension with the thumbwheel (fig. 13, A) on the front fork. You turn it clockwise to make the suspension stiffer, anticlockwise to make it softer. Take care to ensure that the tension is the same both sides. If necessary, you can achieve this by zeroing both sides. If you then see to it that you adjust both sides by the same number of turns, you will be sure that the tension is equal in both suspension units.

Ultimate Speed and Medeo Speed models front fork (figure 13.1)

Spring tension can be altered using the left-hand thumbwheel (viewed from the seated position on the bike) (fig. 13.1, A) on the front fork. Turn clockwise to increase spring tension; anticlockwise to reduce spring tension. The suspension can be locked out using the thumbwheel on the right-hand leg. (fig 13.1, B) Turn it clockwise to lock out the suspension. In the lockout setting, the fork still compresses slight under heavy loading.

Internal headset suspension

You set suspension stiffness by means of the small bolt under the head tube, between the two legs of the fork (see fig. 15). You turn it clockwise to make the suspension stiffer; to make it softer you turn it anticlockwise. Whenever you want to adjust the internal headset suspension, you will need to slide the rubber sleeve down in order to expose

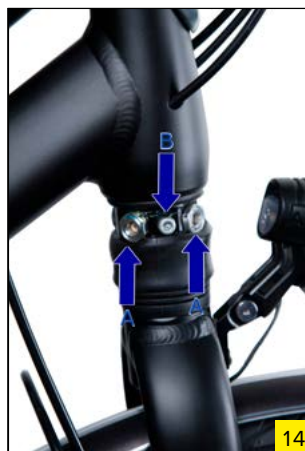
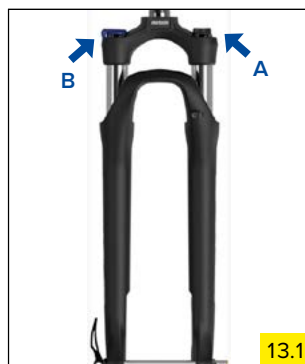



the adjustments system (**see fig. 14**). Unscrew nuts **(A)** with a 14 mm open-ended spanner. Tighten the 4 screws **(B)** using a 6 mm Allen key to remove any play. Tighten each opposite pair of screws **(B)** together. Repeat until all play has been eliminated. If, by any chance, the screws **(B)** are a little too tight, unscrew them alternately so as to eliminate excessive friction. Ensure the 4 screws **(B)** are tightened evenly. The fork is adjusted correctly if there is no play while the fork is still able to move smoothly. Tighten all nuts **(A)** to prevent the bolts from coming loose. Refit the rubber sleeve to seal off the fork.

Now check the fork movement. If it is in order, vertical movement will be smooth and there will be no lateral or fore and aft play. If one of these criteria is not met, repeat the entire process as often as necessary in order to achieve smooth movement without play.

3.2 Maintenance

Dirt and moisture can get into the mechanism as it moves up and down, thus reducing its effectiveness. That is why the suspension needs to be cleaned regularly, under the rubber gaiters as well. The suspension is best kept clean using a moistened soft brush. After cleaning, the suspension mechanism needs to be oiled with Teflon-containing oil.

To lubricate the fork itself, it needs to be taken apart. This is a specialist job! Accordingly, make your way to your Gazelle specialist: he has the expertise required to carry out this job in his workshop.

4. Lighting

As a cyclist, it is most important to be seen by other road users in order to be able to negotiate traffic safely. In this chapter you will read all about the operation of the various types of lighting you can come across on your Gazelle bike.

4.1 Controls

Front light

Most front lights are powered by a hub dynamo. Only the Trelock LS 330 and the Spanninga Swingo front lights are battery-powered.

The Tung Lin is powered by a bottle dynamo: you need to click it onto the tyre sidewall first.

Gazelle front lights are switched on via the on/off, slide or rotary switch. See figures 16 to 24 for a summary of all front lights and the location of the on/off switch. Pressing switch **(A)** once switches the lighting on; press it again to switch off the lighting completely. The Busch & Müller front light **(fig. 25, see next page)** does not have an on/off switch: you operate it via the e-bike display.





25 Busch&Muller Lumotec IQ Cyo

Do you have a Trelock LS 330 front light? Then your light has three positions. Press once to switch the light on; press twice for the flashing function and three times to switch it off.

With most front lights, you can simply move the body to direct the light beam. If you have a bike with the Gazelle FenderVision front light, then you can alter the position of the front light and hence the light beam using the black slider on the left-hand side. You will see two bulbs in the Tung Lin front light: the second one is a spare.



25.1 Ultimate Speed

Ultimate Speed front light (figure 25.1)

The lighting on the bike will come on as soon as you switch the bike on. You do this by pressing the on/off button on the display. The lighting will only work if the battery is in the bike and sufficiently charged.

You can aim the front light up or down by hand. Be considerate to other road users, which is why you should aim the light towards the ground and thus avoid blinding fellow road users.

WARNING: The front light may be hot if it is or has been on for some time.



26 Spanninga O-GUARD

Rear lighting

The latest generation of Gazelle rear lights has been designed to last a long time. The LED lights consume very little power and have a very long lifespan. The use of batteries to power rear lights has consigned wiring problems to history. You switch the rear lighting on using the button **(A)** (figs. 26 to 33). If you have a Herrmans, SlimVision or AXA Riff rear light, then you have three positions: on, auto and off:



27 Spanninga Brasa



28 AXA Riff



29 Gazelle SoloVision



30 Gazelle LED XB & Gazelle nr. 7

On: use this to have the light on all the time. This can be useful for instance in misty weather when it is desirable to have a rear light on, whilst it is still too light to switch on the automatic function.

Auto: in this position, the rear light switches on automatically as soon as it gets dark and the bike starts moving. When you stop again, for instance at a traffic light or at the end of your trip, then the rear light will stay on for another minute (sidelight function).

Off: use this to switch the light off completely all the time. This is useful when you carry the bike on your car: in these conditions it is not desirable to switch on the light as it could be a nuisance to other road users. You choose the setting by the number of times you press the sliding button (once for on, twice for auto, three times for off). On the Herrmans rear light you will see a yellow LED light up on the reflector when you have switched it to the auto setting.

The other rear lights (Spanning Brasa, Gazelle BE Vision, Axa Spark and Gazelle No. 7) only have an on and off setting, operated using the button **(A)**. Do you have a Spanning Brasa light? This light has an indicator on it. Once the remaining charge in your batteries is down to 6 hours (or less), the indicator will turn red.

4.2 Repairs

Front lighting

Should the lighting fail to work, then the problem is likely to be in the wiring. It could be a broken cable, or the connections may have worked loose. Start by checking the dynamo connection: is the cable connected properly to the dynamo? Check the connection of the cable to the light next. If both connections appear to be sound, it is likely to be a broken cable, in which case the cable will need to be replaced. You can make your way to your Gazelle specialist for this.



31 BE Vision & SlimVision



32 AXA Spark



33 Hermans/Racktime



34 Trelock LS330



35 Trelock LS330



36 Spanninga Swingo

Do you have a Trelock LS 330 or Spanninga Swingo front light? If so, it is likely that you will need to replace the battery. If you have a Trelock LS 330 front light (see figs. 34 and 35) the procedure is as follows: press (B) in and slide the light out of its holder. Underneath the detached light you will find a red button (C); slide this button forward. This allows you to slide the cover of the light off and replace the batteries.



37 Spanninga Swingo

Do you have a Spanninga Swingo front light (see figs. 36 and 37)? To replace the battery, you will need to prise the lens off the light using a coin in the indentation (B).

If the LED lighting still fails to light up even though the cables and/or batteries are in order, then the fault can lie in the electronics. It may also be the case that the bulb has blown. You Gazelle specialist can check this out for you and replace the defective components as necessary.

Rear light

Rear lights on Gazelle bikes are fitted with LED bulbs with a very long lifespan. However, if your light is not working, it is likely to be the batteries that are due for replacement.

On the Herrmans, Spanninga Brasa, SlimVision, BE Vision,



38 Herrmans integrated into carrier



40 Spanninga Brasa



42 BE Vision & SlimVision



39 Herrmans/Racktime



41 Spanninga Brasa



43 BE Vision & SlimVision

Gazelle LED XB, Gazelle No. 7 and Solo Vision rear lights, you need to remove the screws **(B)** (see figs. 38 to 47).

You can then remove the cover or slide, after which you can replace the batteries. NB: on the Solo Vision and the AXA Riff, the screw is located behind the on-off sliding button: the screw is visible when the light is switched off. If you have an AXA Spark or Spanninga O-GUARD rear light (see figs. 48 to 51), then you can remove the cover using a coin in the indentation **(B)** (AXA) or at the on-off button (Spanninga).

Always ensure you fit the batteries with the orientation shown in the rear light. Also be sure to use Alkaline batteries exclusively since they don't leak, thus precluding damage.

If your rear light with the new batteries fails to light up, it is likely that the battery contacts have become dirty. Please refer to your Gazelle specialist if this is not the case.



44 Gazelle SoloVision



45 Gazelle SoloVision



46 Gazelle LED XB & Gazelle nr. 7



48 AXA Spark



50 Spanninga O-GUARD



47 AXA Riff



49 AXA Spark

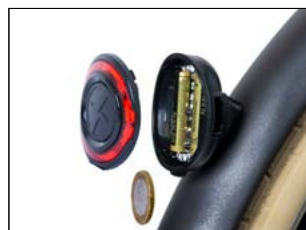

51 Spanninga O-GUARD

5. Brakes

Brakes are of crucial importance for your safety. This chapter will tell you all you need to know about adjusting and maintaining your brakes. Do you have hand-operated brakes? If so, the left-hand lever operates the rear brake and the right-hand lever operates the front brake.

NB

- Do you have a bike with front suspension? If you brake hard, then the front suspension will cause fore-and-aft rocking which can be hazardous in bends. This effect is mitigated by using both front and rear brakes. This means you should never brake with the front brake on its own!
- Your brakes have a longer stopping distance in wet weather, be sure to allow for this!



52

5.1 Adjustment

If you feel the brake lever pulling all the way without applying the brakes fully, then you will need to tension the cable using the adjusting screw (**fig. 52, A**) on the brake lever mount on the handlebar. Unscrew the adjusting screw by a couple of turns. Next, tighten the lock nut against the brake lever mount so the adjusting screw cannot work loose while riding the bike. Take care to ensure that the indentation on the adjusting screw is facing downwards, otherwise it can fill up with rainwater.

Do you want to adjust the position of the brake levers relative to the handlebar grips? Use the adjusting bolt (**fig. 52, B**) to change the position of the brake lever.

5.2 Maintenance and repairs

Do your brakes work less well in the winter? It could be that your brake cables have frozen solid. If this is the case, your cables will need to be re-lubricated. This is a specialist job: we would advise you to go to your Gazelle specialist for this.

V-brake

The V-brake system is relatively simple: you brake by means of the brake blocks, which press against the wheel rim when the brakes are applied. If you notice your V-brakes losing braking power, it could mean that your brake blocks are worn out. Check the brake blocks for wear by looking to see whether the grooves are still visible on them. If the blocks are worn down to the bottom of the grooves (to around half a millimetre) then they must be replaced.

To replace the brake blocks, you need to release cable **(A)** above the brake first (see fig. 53). Unscrew bolt **(B)** next, using a 5 mm Allen key. You can now remove the brake blocks and replace them with new ones. Take care to ensure you fit the correct type of brake block! If you buy the wrong kind of brake block, you could damage the rim. Make sure you fit the left-hand brake block on the left-hand side and the right-hand one on the right-hand side.



After replacing them, check the gap between the brake blocks and the rim. If this is excessive, you will have insufficient braking power; if it is too small, they can rub against the rim. Use an ideal gap of 2 mm as your starting point. If the gap is greater than this, you can reduce it using the adjusting screw **(A)** on the brake lever (see fig. 52). Ensure the front end of the brake blocks is slightly closer to the rim than the rear, otherwise the brakes will squeal. V-brakes can cause the rims to wear. This effect is accelerated by contamination such as sand or street grime. Accordingly, clean your brakes frequently, using water or a brush, for instance, and have your rims checked regularly by your Gazelle specialist as to whether they are still stable or need replacing.

NB

V-brakes are very powerful. Do not therefore use the front brake on its own, always use the front and rear brakes together! Some Gazelle V-brakes are equipped with a power modulator to apply the braking power more gradually. This prevents the brakes from being applied too abruptly, producing a short delay before full braking power is applied.

Drum brakes

A drum brake is fitted in the hub of the wheel. The brake system consists of a brake drum that rotates with the wheel; inside the drum there are two brake shoes which do not rotate with the wheel. When you brake, the brake shoes are forced against the drum: this brings the wheel to a standstill. Drum brakes wear out with the passage of time. You will become aware of this when the brake levers are almost able to touch the handlebars. All it usually requires is to adjust the brakes. Push the lever **(A)** upwards (see **fig. 54**). Then screw the nut **(B)** in to the point where the brake just catches, then unscrew it just a touch so it is just clear and the wheel spins freely. Apply the brakes firmly at regular intervals while you are adjusting them. Take care to ensure that the brake cable or pin is located correctly in the lever so it doesn't fly out!

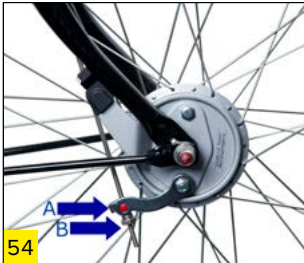

Next lift the bike up and spin the wheel. If the wheel keeps on spinning without sticking, then you have adjusted the brake correctly, otherwise the wheel will stop abruptly. In the latter case you will need to back the nut off again by one or more turns.

The same procedure can be followed if you have rod-operated brakes. You just need to ensure you adjust the front brake first before starting on the rear.

Brake shoe replacement should be left to the Gazelle specialist when required. He is the only one who can determine the type of brake shoe that needs to be used.

Roller brake

The Shimano roller brake (see **fig. 55**) is a type of drum brake. Correct adjustment is achieved by twisting the barrel adjusters at the hub **(A)** and at the brake lever on the handlebar (see **chapter 5.1, fig. 52**). The roller brake also has a grease fitting **(B)** to add grease to lubricate the brake. We would advise you to go to your specialist for this. If you top up the brake incorrectly or use the wrong lubricant, you can actually cause serious damage to the brake! If you still want to lubricate the brake yourself, bear in mind that you must only use Shimano roller brake grease.



Hydraulic brakes

Gazelle bikes can be equipped with hydraulic disc brakes (**fig. 56**) or hydraulic rim brakes (**fig. 57**).

A disc brake consists of 2 moving brake blocks. A reduction in braking power can be an indication of air in the brake lines; you need to make your way to your Gazelle specialist for this.

If you have hydraulic rim brakes, check the brake blocks on a regular basis. If the blocks are worn down to the bottom of the grooves (**to around half a millimetre**) then they need to be replaced.

Unscrew the brake cylinder mount top bolt (**A**) first using a Torx T25 wrench and remove it. Unscrew the bottom bolt (**B**) next using the same Torx wrench so the brake cylinder can rotate by a quarter turn. You can now remove the brake block and replace it.

Once you have replaced the brake blocks, you press the brakes against the rim so the brake blocks are positioned parallel to the rim. Check the brake blocks to ensure they press straight on the rim. Take care to ensure that the brake units are not skewed, but aligned to each other.

Press the brake lever carefully and tighten the bolts once the brake blocks are pressed in around 2 mm from the rim. Observe the specified tightening torques!

NB

- Brake discs must be kept free from oil, grease or wax!
- If you have traces of oil on the levers or brake lines, you need to make your way as soon as possible to your Gazelle specialist, since this can indicate a leak!

Coaster brake

If you notice a reduction in the stopping power of your coaster brake, then refer to your Gazelle specialist. Maintenance and any repairs of this brake system are specialist jobs which can only be done properly by a specialist.





58



59

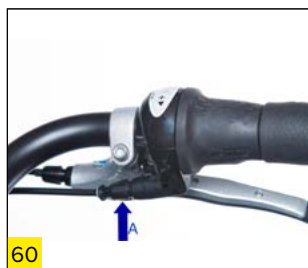

60



61



62

6. Gears

Gazelle bikes can be fitted with a Shimano, NuVinci or Sturmey-Archer internal hub gear with 3, 7, 8 or 11 speeds, or a derailleur system. The gears will of course be correctly adjusted on delivery. With the passage of time, however, it may be necessary to adjust them again. In this chapter you will read how to do this; you will also find information about maintaining your gears.

6.1 Internal hub gear adjustment

Shimano (Nexus 3, 7, 8 and Premium 8, Alfine 8 & 11)

Select the right gear first (see fig. 58): Shimano Nexus 3 internal hub gears are adjusted in second gear; you need to adjust all Shimano 7-speed and 8-speed hubs in fourth gear. Do you have a Shimano 11-speed internal hub gear? Then you need to adjust it in sixth gear.

Rotate the pedals a few turns to be sure that hub itself is actually in the right gear. Next, check whether the coloured bars on the shifter unit (see figs. 59 and 61) are in line. If this is not the case, turn the adjusting screw (A) on the shifter unit (fig. 59) or on the shifter (fig. 60) until the bars are aligned. The gears are now adjusted correctly.

NuVinci Harmony (automatic) & Manual

In automatic mode, the NuVinci Harmony system (see fig. 62) adapts the gear ratio automatically so you can maintain the desired cadence. You set the ideal cadence by rotating the handlebar grip. The blue “RPM” LED indicates the cadence setting.

You can shift gears yourself in the manual mode using the “ride by wire” technology. The orange “hill” on the LED display indicates that the steeper the hill, the lower the best gear to climb it is.

With the NuVinci Manual shifter (see fig. 63) you can enjoy stepless shifting. This means you change gears very gradually rather than in jumps (e.g. from 2 to 3). As a result of this, you will enjoy smooth and effortless shifts and the

ability to select the ideal gear for any situation. The NuVinci hub also boasts a wider range than many traditional shift systems.

NB

Are you noticing that you are having to pedal harder in the lowest gear and/or too easily in the highest gear? This means your range has narrowed (see table 3, chapter 21); in this case the gears will need to be adjusted using the adjusting screw. The best thing for this is to take it to your specialist, since this is a painstaking task.

If your NuVinci Harmony has been re-installed, or if the system is working inconsistently or even incorrectly, you will need to calibrate the system. To do this, switch the system on first. Ride the bike gently throughout the entire calibration procedure.

To start the calibration program, press the “mode” button (fig. 62, A) on the Harmony H8 controller and hold it down until the rear hub starts to shift (usually 5-7 seconds). After that release the button. Keep on pedalling gently while the system shifts several times from “low” to “high” and completes the calibration process.

N.B.: the Harmony manual cannot be calibrated.

Sturmey-Archer

If your bike has a Sturmey-Archer internal hub gear, set the shifter (fig. 64) to the middle gear. Next, turn the pedals a few times so you can be sure that the hub itself is also in the middle gear. Now unscrew the nut (A), and twist the sleeve (see fig. 65). The end flat of the control rod (B) must be flush with the end of the axle. You can see it through the opening in the axle nut. Next, tighten nut (A) again. You can check whether the adjustment is correct by shifting a couple of times, and looking to see if the setting returns to the initial position. If everything is in order, you can clip the rear section of the chain case back on.

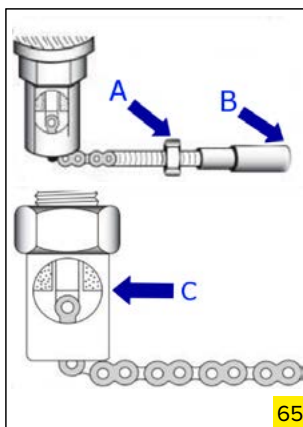

6.2 Internal hub gear maintenance

Do your gears shift less well in the winter? It could be that your gearshift cables have frozen solid. If this is the case, your cables will need to be re-lubricated. Lubricating cables is a specialist job: we would advise you to go to your specialist for this. If the oil in the hub itself needs changing or filling, this is a job for your Gazelle specialist.



66

6.3 Derailleur gear controls

On the indicator, the highest number indicates the highest gear and the lowest number the lowest gear. The shifter that operates the front derailleur (**A**) is always on the left-hand side and the shifter for the rear derailleur (**B**) on the right-hand side (see fig. 66). If you press the shifter once or shift its position, then you will always shift the front or rear derailleur up or down one sprocket. You need to keep on pedalling when shifting gears on a derailleur bike. It is desirable, however, to ease up on the pedal pressure while shifting.

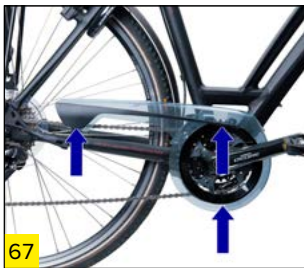

67

6.4 Derailleur gear adjustment

Start by removing the chain guard by removing the 3 screws indicated by blue arrows (see fig. 67).

Adjusting the front derailleur bottom gear

Place the chain on the largest sprocket at the rear, and the smallest chainring at the front. Use adjusting screw (fig. 68, **A**) to set the clearance between the inner face of the chain guide and the chain to a maximum of half a millimetre.



68

Adjusting the front derailleur top gear

Place the chain on the smallest sprocket at the rear, and the largest chainring at the front. Use adjusting screw (fig. 68, **B**) to set the clearance between the inner face of the chain guide and the chain to a maximum of half a millimetre.

Adjusting the front derailleur intermediate gear

Place the chain on the largest sprocket at the rear, and the middle chainring at the front. The clearance between the

inner face of the chain guide and the chain can be set to a maximum of half a millimetre using the adjusting screw on the shifter on the handlebar (see fig. 60, chapter 6).

Adjusting the rear derailleur top gear

Turn adjusting screw (fig. 69, A) to adjust the top gear. Ensure the chain is on the outermost sprocket and turn the adjusting screw until the jockey wheel, viewed from the rear of the bike, is directly in line below it.

Adjusting the rear derailleur bottom gear

Turn adjusting screw (fig. 69, B) to adjust the bottom gear. Ensure the chain is on the innermost sprocket and turn the adjusting screw until the jockey wheel, viewed from the rear of the bike, is directly in line below it. Now check second gear. If the chain is interfering with an adjacent sprocket, this can be adjusted out using cable adjusting screw (fig. 69, C). In some versions the adjusting screws are in a different position on the derailleur. Adjustment is as described above.

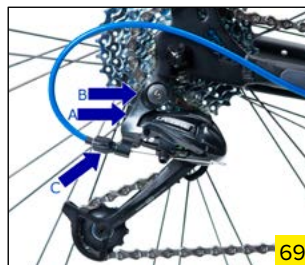

NB

The chain should follow a straight line as far as possible. This means that shifting to some combinations is pointless and causes needless wear to the chain, chainrings and sprockets. If the chain is running on the smallest chainring at the front, avoid running it on either of the two smallest sprockets at the rear. If the chain is running on the largest chainring at the front, avoid running it on either of the two largest sprockets at the rear. Combining the middle chainring at the front with the smallest or largest sprockets at the rear is also inadvisable (see fig. 70).



6.5 Derailleur gear maintenance

The cassette transmits the motion from the to the rear wheel, causing it to rotate. On our derailleur bikes this cassette can consist of 8, 9 or 10 sprockets. An accumulation of dirt or improper chain tension can cause rapid wear in these sprockets. Should this be the case, it can cause chain damage or annoying “skipping”. In this situation there is nothing for it but to have the cassette replaced. Proper and regular maintenance prolongs the cassette’s

lifespan. Accordingly, remove the dirt that accumulates on the cassette regularly and with care. You should remove the worst of the dirt with a brush, you can then pour a special chain or derailleur cleaning fluid onto it. In addition, ensure that there is no dirt left behind between the sprockets either. You are best removing this with a paintbrush. Once the cassette has dried off properly after cleaning it, you can lubricate it with derailleur oil.

7. Chain and belt drive

7.1 Adjustment: chain tension

In order to be able to ride your bike comfortably it is of the utmost importance that the chain be tensioned correctly. If the chain is too tight then extra effort is needed to get the bike going. Moreover, you run the risk of damaging the wheel bearings, chainrings, sprockets or the bottom bracket bearings. If there is too much slack in the chain, it is likely to come off the chainrings. Have your chain tension checked regularly by your Gazelle specialist. The Gazelle Flowline chain case (**see figs. 80 and 81, chapter 8**) features an automatic chain adjuster; you don't need to adjust the tension on this one. However, it does need to be done manually with all the other chain cases.

To tension the chain, you need to slacken the axle nuts (**A**) first. Tightening the nut (**B**) increases the chain tension (**see fig. 71**). On some models you can access the chain directly; on other bikes you will need to remove the end cap from the chain case first. In chapter 8 (**chain cases**), you can read more about the various types of chain case and how to remove the end cap from them.

Once the chain tension has been set correctly, all you need to do is to retighten the axle nuts (**A**) and the brake arm bracket (**C**) properly. When doing so, check the wheel is completely straight and in line with the front wheel. This will be the case if the gap between the wheel and the chain stays is equal both sides.

7.2 Maintenance

It is important that the chain (**fig. 72**) be cleaned and lubricated from time to time. Do this as follows: ensure the rear wheel is clear of the ground by placing the bike on a stand, suspending it or upending it. Turn the pedals backwards and spray the chain on the rear sprockets with a degreaser. This provides a protective, dirt-repellent coating. After that, lubricate the chain with thin oil, Teflon or silicone spray.

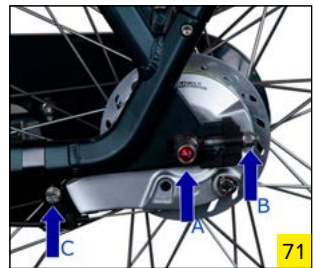

Run the chain around a couple of times, forwards and backwards, to spread the oil well. Remove excess lubricant with a dry cloth.

7.3 Repairs

Is your chain worn out and due for replacement? We recommend you buy a chain of the same make and type. Take care to ensure the chain has the same number of links and is of the same roller width.



73

7.4 Belt drive adjustment

The belt drive system (**see fig. 73**) is suitable for all weather conditions which means it can be used all year round. Take care to ensure that the belt is not distorted or under tension, due for instance to an object resting on the belt when you park the bike.

Insufficient tension can cause “skipping”. When skipping, the belt teeth slide over the sprockets and it feels like wheel spin to the cyclist. Skipping poses a risk of injury. Excessive pretension can result in increased component wear due to overloading. The bottom bracket and rear hub bearings can be damaged in this way.

The optimum belt tension is approx. 75 N. This equates to a maximum belt deflection of 25 mm with a 5 kg load applied vertically at the midpoint of the top span. We recommend you go to your Gazelle specialist to have your belt drive tension set.

If you still want to tension your belt drive yourself, please refer to the special belt drive manual at www.gazellebikes.co.uk/service-and-warranty.

7.5 Belt drive maintenance

In order to give your system a long lifespan, we would advise you to clean dust and dirt off your belt drive system periodically. The gaps in the sprocket joints are machined in such a way that dirt particles are usually forced out of the belt tooth running over them. However, compact small stones or twigs can still get trapped in the system. Residues on the belt or on the sprockets can lead to increased wear and noise (**e.g. squealing and creaking**).

Dry cleaning

Ensure that dirt is cleaned off belt teeth (**see fig. 73**) and tooth profiles of both sprockets using a hand brush. You can use a screwdriver for instance with care to remove trapped particles or stones which have been picked up.

Wet washing

In order to remove stubborn dirt, (**biodegradable**) bike cleaning products freely available in the trade can also be used, since the belt is resistant to soap. Spray the drive system, allow it to penetrate, then use a sponge to obtain a foam and clean off. An old toothbrush is particularly suitable for stubborn dirt in the belt and sprocket gaps. Follow this by washing the drive system down abundantly with water.

If the noise generated still persists despite thorough cleaning, the inside of the belt can be given a thin coating of dry silicone spray. This will protect against further ingress, improve the belt's sliding characteristics and reduce noise generation.

Do you want to find out more about belt drive operation, maintenance and adjustment? If so, please refer to the special belt drive manual at www.gazellebikes.co.uk/service-and-warranty.

8. Chain case

It may be necessary occasionally to remove the chain case partially, for instance if you want to remove the rear wheel or lubricate the chain. In this chapter you will read how to do this with the various chain case models.

With the Gazelle Next chain cases, you can slide the cap on the back end of the chain case off by hand (**figs. 74 and 75**).



74

If your bike is fitted with a Gazelle Linea chain case, then you will need to unclip the end cap off the top lip using a screwdriver (**see figs. 76 and 77**). After that you can unclip the end cap off the bottom lip by hand. You can then slide the cap rearwards.

The Gazelle Balance chain case can only be removed in its entirety. You do this by unscrewing all four screws (**see figs. 78 and 79**). You can then remove the entire chain case from the bike.



75 Next

If your bike is fitted with a Gazelle Flowline, Finura, Agudo, Xcero, Delgado or Cadena chain case, you can disassemble the end cap by removing the screw first using a screwdriver (**see figs. 80 to 87**). Continue pulling it free by hand from the bottom and slide the cap rearwards.

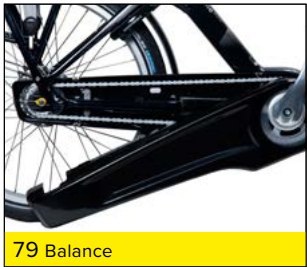
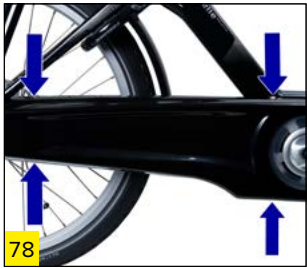

9. Bottom bracket, cranks and pedals

9.1 Maintenance

The pedals on your bike are attached through the cranks to the bottom bracket. There is nothing you need to worry about here, since the bottom bracket as well as the pedals are manufactured as “sealed units”. This means that you never need to lubricate them.

It is a good idea nevertheless to pay some attention to these components. Accordingly, the cranks must be secure and they must not show any play. If this is the case you will hear an irritating grating noise as you pedal. What is more, a loose crank can cause irreparable damage to the bottom bracket. However a small amount of play in the pedal bearing is allowable. This is because the pedal spindle will bend a little with the passage of time due to the force exerted on it.

If the pedals themselves or the cranks are damaged following a fall for instance, they will need to be replaced. If you bend them back, the material structure can actually change to such an extent that they could well fail of their own accord at a later date.



88



89

9.2 Repairs

Do you want to replace the pedals? Then you can remove them (**see figs. 88 and 89**) with a 15 mm open-ended spanner on the flats (**A**) or with a 6 mm Allen key directly on the inner end of the spindle (**B**). Pedals do need to be fitted on the correct side, which is why they are marked L and R. When the pedals are fitted correctly, you screw them on in the direction of the front wheel and unscrew them in the direction of the rear wheel.

NB

You pedal can become slippery in wet weather, even if you have non-slip pedals.

10. Bike stand

Some Gazelle bike stands are height-adjustable. You can adjust the stand using the button **(A)** (see figs. 90 to 92) or screw/screws **(B)** (CL-KA63, Atran/Velo and Power Click, see figs. 93 to 97). Press the button in or slacken the screw/screws; you can then adjust the height. If the stand uses screws, you need to tighten them again after you have adjusted the stand.

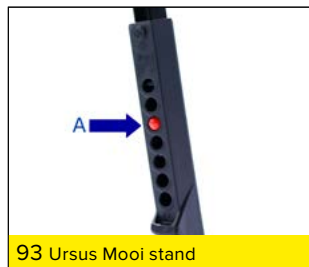
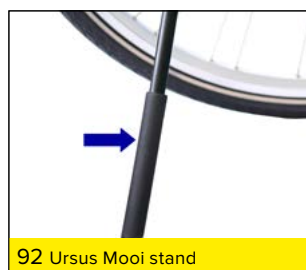

11. Wheels

11.1 Adjustment

Some Gazelle models are fitted with quick-release hubs (see fig. 98). The quick release must be tightened properly to prevent the wheels from coming loose. To adjust this you need to open the lever. Then tighten the nut at the other end of the skewer by hand until it is just finger-tight. Finally, flip the lever over to the closed position (as shown in fig. 98). This is the only way to secure the wheels correctly. Take care not to apply excessive pre-tension otherwise the quick-release skewer can snap.



11.2 Repairs

If your wheel is buckled we recommend that you involve your Gazelle specialist as soon as possible. Repairing a wheel is actually a specialist job. The same applies to repairing a broken spoke. If there is a broken spoke the wheel can distort which increases the likelihood of more spokes breaking.

The hub is the heart of the wheel. If there is play in a wheel or if it does not spin freely, then it is almost always due to hub problems. In such cases pay your Gazelle specialist a visit directly, he is the only one capable of remedying this problem quickly and expertly.

Check the rim regularly for excessive wear. A worn rim will be hollowed out: you can check this by placing a ruler against the side of the rim. If in doubt, we would advise you to have the rim checked by your Gazelle specialist.

11.3 Removing a wheel

Front wheel

If your bike is fitted with quick-release hubs (see fig. 98), then you can remove the wheels from the bike very easily. When you flip the quick-release lever open and remove the front hub dropout protector, the wheel will drop out of its

own accord. V-brakes (**both regular and hydraulic**) need to be opened out when removing the front or rear wheel (**see chapter 5, brakes**). When you want to refit the wheel, take care to ensure that there is sufficient tension in the quick release skewer. This will prevent the wheel from parting company with the fork.

On bikes without quick-release hubs, all you need do is unscrew the axle nuts.

Ultimate Speed front wheel removal

The front wheel on the Ultimate speed is fitted with a thru-axle. The quick-release lever (**A**) needs to be released in order to remove the wheel. Next, the locking mechanism (**B**) needs to be pressed in. The axle can now be removed. The locking mechanism should be checked thoroughly when being fitted.

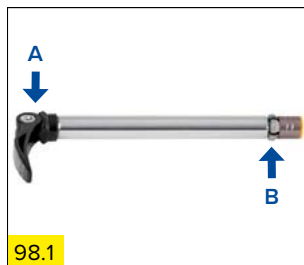

Rear wheel

If your bike is fitted with a chain case, in most cases you will start by removing the rear cap on the chain case. If you have a Gazelle Balance chain case, then it needs to be removed in its entirety. See chapter 8 (**chain case**) for more information about removing the rear cap or chain case. If you have a varnished fabric chain case, you need to release the button at the rear in order thus to open out the varnished fabric.

If your bike is fitted with a Sturmey-Archer 3-speed internal hub gear, then you can disconnect the hub by unscrewing the connector between the cable and the chain. If you have a Shimano Nexus 3 internal hub gear, then you can remove the shifter unit from the hub axle with a bolt.

Now unscrew the nuts on the wheel axle (**A**), the chain tensioners (**B**) and the brake arm (**C**) (**see fig. 99**). Then push the wheel forwards up to the end of the slot. You can now remove the chain from the sprocket. If you then pull the wheel rearwards, you can drop it out of the frame. To refit the wheel back in the frame, you follow the above instructions in reverse order. Please refer to the instructions in chapter 6 (**gears**) for the correct adjustment of the internal hub gear.

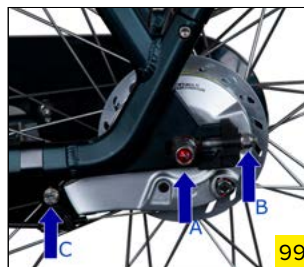

If your bike is fitted with a Shimano 7, 8 or 11 internal hub gear, then the procedure for removing the rear wheel is slightly different. Select first gear on the rear hub. Disconnect the gear cable at the bottom bracket and the down tube. You can pull the wheel rearwards by about five centimetres. Next, unscrew the nuts on the wheel axle **(A)**, the chain tensioners **(B)** and the brake arm **(C) (fig. 99)**. After that, push the wheel forwards to the end of the slot and remove the chain from the sprocket. Next, pull the wheel rearwards, to enable it to be dropped out of the frame. The wheel has now been removed. If you rotate the lock ring **(on the opposite side of the wheel)** counterclockwise, you can now remove the shifter unit as well. Leave the cable on the shifter unit, otherwise you will lose the correct adjustment.

To refit the rear wheel back in the frame, you follow the above instructions in reverse order. When fitting the shifter unit, take care to ensure that the yellow marking dots on the hub and the shifter unit are aligned.

12. Tyres

12.1 Maintenance

It is recommended that tyre pressures are checked regularly. Well-inflated tyres generate much less rolling resistance than underinflated tyres, which means less effort when cycling. What is more, your bike will respond better to your steering and braking input. Furthermore, underinflated tyres wear faster and are more liable to get punctures. The rim can also wear more rapidly if your tyre pressure is too low.

If you are able to press your thumbs into your tyres just a little, it means that they have enough air in them. If you have a bicycle pump with a pressure gauge, then you can read the recommended pressure off the tyre sidewall. The tyres on an ordinary bike need to be inflated to between 3.5 and 6 bar. The exact recommended tyre pressure is shown on your tyre sidewall.

If you are not using your Gazelle for an extended period, during the winter for instance, it can have an adverse effect on your tyres.

Check the tread on your tyres regularly. If the tread is almost gone, or you can see the canvas in places, the tyre will need replacing. In addition, if you see small cracks in the tyre or get punctures significantly more often, it means you are due for a new tyre. In chapter 12.2, you will read how to take the tyre off the wheel. You need to take the wheel off to replace the tyre; chapter 11.3 explains how to do this.

12.2 Repairs

If you have a flat tyre check first whether the valve has failed. Do this by wetting the valve opening a little; if any bubbles appear, then the valve is leaking. Check first whether the problem can be remedied by cleaning the valve. If this doesn't help, then you need to replace the valve. If the valve is working correctly and the tyre still goes flat,



then it has a puncture. To repair the puncture, you need to remove the valve and the rim nut first (upend the bike to do this). Press the edge of the tyre towards the centre of the rim and push the first tyre lever between the tyre and the rim. Take care not to pinch the inner tube while doing so to prevent further punctures. Now insert the second tyre lever right next to the first one and slide it over around a hand's width. Repeat this with the third one. Remove the second tyre lever next (if it hasn't fallen out of its own accord) and insert it next to the third one. Repeat the procedure until you have freed the tyre from the rim.

Now push the valve stem out and withdraw the inner tube from the tyre. Refit the valve in the inner tube again and inflate the tyre. If there is a large hole in the tube you will hear the air escaping at once. You can locate a small leak by holding the tube down in a bowl of water. Once you have found the puncture, mark the spot with a pen and then let all the air out of the tube and dry it off.

Clean the area around the hole thoroughly with a small piece of emery cloth. Next apply a coating of solution sparingly and allow it to dry for a few minutes (follow the instructions with the solution). Cut out a patch to the right size and stick it on the puncture. Apply firm pressure to the patch and hold it down for a bit. Leave to dry for a few minutes. Now check the tyre casing for sharp objects (glass, nails and the like) and remove them to prevent any further punctures. In order to verify whether the puncture has been sealed you can inflate the tube again and draw it through the water. If the puncture has been corrected refit the tube over the rim. Feed the valve stem through the hole in the rim first. Then fit the rest of the inner tube; ensure that it is not folded over or twisted at any point. Inflate it slightly as necessary. Ensure that the rim tape is correctly centred as well, since it protects the inner tube from the spokes.

Now fit the tyre working around the rim starting from the valve by pressing it into the rim (this may require quite a lot of force in the final section). Keep the valve stem pressed in as far as possible, this will ensure that the inner tube is positioned correctly. Press the tyre into the rim again. Do

not use tyre levers to refit the tyre: doing so risks puncturing the tyre again!

If the tyre has been fitted correctly, inflate the tyre and then tighten the valve nut securely. Screw the dust cap onto the valve and you are ready to go.

If the hole in your inner tube is too big to be repaired, then it will need to be replaced. You will need to remove the wheel for this. Chapter 11.3 explains how to do this.



101

13. Saddle

The saddle is an important component of your bike. There are various types of saddle: the saddle on a racing bike is hard and narrow, the saddle on a more comfort-oriented bike is wider and softer. Gel saddles are fitted on many models. These saddles can mould themselves to the rider and distribute the pressure on the rider's seat over the saddle. Gel saddles must not be left in the sun for too long; this can actually overheat the filling.

Adjustment

The best way to test the height of your saddle is by sitting on the bike. You must be able to touch the ground with the toes of one foot while you rest the heel of your other foot on the pedal at bottom dead centre. Your leg should then be almost fully stretched but still feel relaxed (see fig. 101). If you have the ball of your foot resting on the pedal, your leg will be slightly bent. If you can touch the ground with both feet, then your saddle is set too low. If you go frequently on long sporty rides, then you are best angling the nose of the saddle slightly downwards. If you use your bike mainly for short trips, then it is usually more comfortable to sit upright and angle the saddle slightly upwards.



102



103



104

If you want to adjust the height of your saddle (see figs. 102 to 107) then all you need to do is slacken the bolt (A) (13 mm open-ended spanner) or the socket head cap bolt (5 mm or 4 mm on Ultimate models) on the chain side. You can then adjust the saddle as you wish. Tighten the bolt firmly once you have finished. Bolt (B) enables you to adjust the saddle fore and aft and set the saddle angle (C). You will need a 5 mm Allen key for both of these bolts.



105

Do you have a suspension seatpost (figs. 106 to 108)? Adjust the lateral play with the socket head cap bolt (D) using a 4 mm Allen key. You can adjust the stiffness of the suspension at the lower end of the seatpost (fig. 108, E) using an Allen key (6 mm). Turning it clockwise increases the spring tension, turning it in the opposite direction reduces tension.

NB

- Ensure you tighten all bolts to the specified tightening torques (see chapter 21, table 1). If you don't do so, your saddle can suddenly shift while you are on the move!
- You must never adjust the saddle while riding the bike!
- Do not set your saddle too high. The 'min' mark on the seatpost must never come out above the seat tube. The seatpost can bend or break if you set the saddle too high!

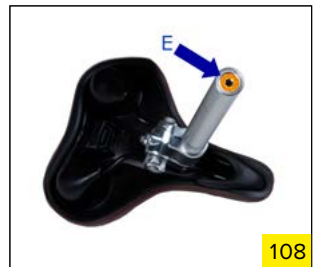

14. Frame

Proper maintenance will prolong your new Gazelle bike's lifespan. That is why it is wise to check it or have it checked regularly and keep it properly clean. You are best using a regular brush or paintbrush which is not too hard. This will remove the worst of the dirt. Take care to avoid scratching! You can then remove any residual dirt using a clean cloth or even better a flannel polishing cloth.

Wash your bike working from the top down with a brush and hot soapsuds. Clean the chain with an old toothbrush. Don't forget to remove the dirt from under the mudguards. Rinse the bike off next with a garden hose. Don't use a spray head with too strong a jet or a pressure washer! This will actually squirt water into the bearings in the internal hub gear, bottom bracket, suspension, etc. Leave the bike to dry properly.

If you need to upend your bike, be sure not to damage the controls on the handlebars and remove loose items such as bags before you set about cleaning the bike.

Paintwork

Every Gazelle bike has as many as four coats of paint. The top coat consists of an environmentally-friendly rock-hard clear powder coating which affords optimum protection against damage. But despite the fact that this coating is highly resistant to chemicals, it is advisable to go about cleaning with care. For instance do not use alkaline cleaners such as ammonia or soda. It is better not to use products containing fluorides, chlorides or sulphates either. These products can actually attack the varnish coating causing it to lose its gloss for example.

The best way to keep the paintwork clean is with a soft cloth and clean hot water. You can add a mild-action liquid soap to it if required.

NB

Never use a pressure washer! The jet of steam or water can actually penetrate right into the bearings or the suspension system where it will force out the grease or oils which are essential for your bike.

Chromium-plated components

Chromium-plated and unpainted components (such as the handlebar, hubs, cranks or the seatpost) are best lightly coated with acid-free petroleum jelly at regular intervals. This forms a protective coating against water, grime and salt, thus preventing these components from rusting.

Many components on your bike, such as the majority of bolts and nuts, are made of stainless steel. This provides better resistance to the elements than chromium-plated or galvanised components for example. Thus, if you give the stainless-steel components a light coating of acid-free petroleum jelly now and then, you will prevent them from corroding over time. Should any rust spots nevertheless appear, you can simply polish them out.

15. E-bikes

Always refer to the electrical system user manual before you are about to use the bike. It contains important safety instructions and warranty conditions relating to the system that is specific to your bike. You will get a quick start manual included as standard with your e-bike. At the same time, you can find a comprehensive manual in electronic format at our website (see www.gazellebikes.co.uk/service-and-warranty).

16. Child seats

If you wish to use a child seat, then there are a number of aspects you need to take into account. If you want to fit a child seat on the front of the bike, choose a model which mounts on the handlebar stem. We advise against fitting a seat that mounts onto the handlebar itself.

This is because current models are fitted with aluminium handlebars and these are not suitable for having a child seat attached to them.

If you opt for a rear seat, then it is important to take account of the maximum load allowed on the rear carrier. You can, if you want to carry more weight, fit a seat with a seat tube mounting. Do not use a child seat to carry children unless it is EN 14344 approved. If you are still, in doubt as to the exact type and/or brand of seat, obtain advice from your Gazelle specialist.

NB

- Carrying another person is only permitted within the framework of the applicable statutory provisions.
- Cover any exposed coil springs under the saddle to prevent the child's fingers from getting trapped in them.

17. Transporting your bike by car

Always use an approved bike carrier to avoid damaging your bike in transit. Your Gazelle specialist can advise you on this.

Check before setting off whether any components can fall off during the journey. Items that come to mind are the bike pump, water bottles or bike bags. Accordingly, always remove these items before loading your bike onto the bike carrier.

On arrival, check whether any components have become detached or perhaps damaged.

Use a bike carrier that attaches to the frame, this provides greater stability in transit than if the bike is held by the cranks. Make sure that the bike does not obscure the car's legally required lighting.

NB

Ensure the automatic lighting is switched off, so it can't light up en route, since this could mislead your fellow road users.

18. Accessories

Are you looking for accessories for your bike such as bike bags, baskets and other items? You will more information on our website www.gazellebikes.co.uk.

19. Theft prevention

Nearly all Gazelle bikes are supplied with an ART-approved security lock. In addition to this, every frame is given a unique frame number. You will find this number on the bike itself and on the purchase receipt you received from your Gazelle specialist. This also quotes the unique key number. If you have lost your bike key, you can order a new one, quoting the key number. If your bike is stolen, then you can report it as stolen quoting the frame number. Accordingly, quote the frame number when making a statement to the police. In order to prevent theft, it is always wise to lock your bike and put away the (spare) keys safely. We would advise you to use an extra chain lock at the same time.

20. Component designations

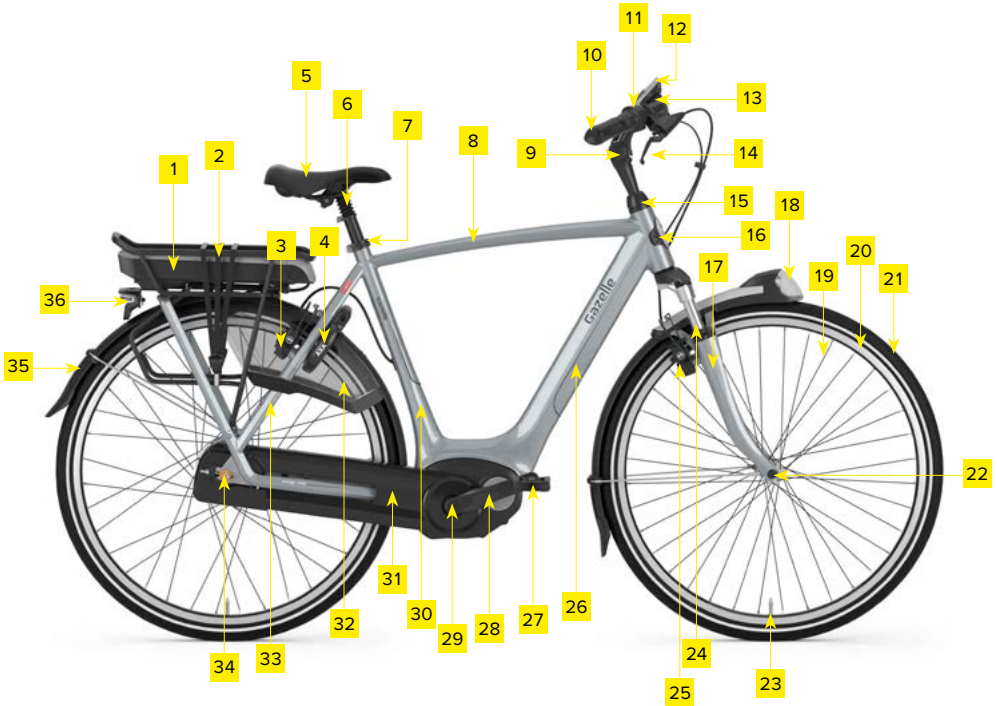

Gazelle

Orange C330 HMB

1. Battery, including charger*	13. Handlebar tube	25. Front brake
2. Clip-on elastic luggage straps	14. Brake lever	26. Down tube
3. Rear brake	15. Headset	27. Pedal
4. Lock	16. Headset nameplate	28. Crank
5. Saddle	17. Front fork	29. Bottom bracket
6. Suspension seatpost*	18. Integral front light*	30. Seat tube
7. Saddle clamp	19. Spoke	31. Chain case
8. Top tube	20. Rim	32. Clothing guard
9. Handlebar stem	21. Webbing	33. Seat stays
10. Handlebar grip	22. Front hub	34. Rear hub
11. Gear shifter	23. Valve	35. Mudguard
12. Display	24. Suspension front fork	36. Rear light

*Depending on model



Gazelle

Chamonix S30

1. Clip-on elastic luggage straps	13. Headset	25. Crank
2. Rear brake	14. Headset nameplate	26. Front derailleur*
3. Lock	15. Front light	27. Bottom bracket
4. Saddle	16. Front fork	28. Seat tube
5. Seatpost	17. Webbing	29. Chain guard
6. Saddle clamp	18. Spoke	30. Seat stays
7. Top tube	19. Rim	31. Rear derailleur*
8. Handlebar stem	20. Hub	32. Mudguard
9. Bell	21. Valve	33. Rear light
10. Handlebar grip	22. Front brake	
11. Brake lever	23. Down tube	
12. Gear shifter	24. Pedal	

*Depending on model

21. Tables

21.1 Tightening torques

Every nut and bolt on your bike has a specified tightening torque. Your Gazelle specialist has special tools for this. If you maintain your bike yourself, you can use a torque wrench to apply the correct tightening torque. These are listed in the table below.

TABLE OF RECOMMENDED TIGHTENING TORQUES	
Handlebar plug bolt	12 – 15 Nm
Expanding bolt with taper wedge	10 – 12 Nm
Nut for seat lug bolt, M8	15 – 20 Nm
Moer voor zadelpenbout M6 binnenzeskant	12 – 15 Nm
Cranks with square	
- Steel	12 – 15 Nm
- Aluminium	30 – 40 Nm
- Shimano	20 – 25 Nm
- Headset nut	35 – 45 Nm
Dynamo	8 – 10 Nm
Hub axle nuts, front wheels	20 – 27 Nm
Hub axle nuts, rear wheels - Sturmey-Archer	20 – 27 Nm
Hub axle nuts, rear wheels	35 – 45 Nm
Hub axle nuts	30 – 35 Nm
Hub axle nuts, Shimano	30 – 45 Nm
Handlebar grips	max. 5 Nm
Internal headset tube suspension nuts	5.9 Nm

21.2 Distance travelled per revolution

This table shows the distance travelled in metres for one complete revolution of the pedals in a given gear. The top row shows the number of teeth on your chainrings and sprockets; the left-hand column shows the gearshift position. If, for instance, you have a 3-speed hub, then in 2nd gear you will travel 4.4 metres per revolution.

DISTANCE TRAVELLED PER REVOLUTION				
Chainring ratio	38-19	38-18	38-18	42-20
Wheel size	28	28	28	28
Gears	3-speed	7-speed	8-speed	11-speed
1	3,23	2,78	2,32	2,12
2	4,40	3,26	2,83	2,74
3	5,98	3,71	3,29	3,09
4		4,35	3,74	3,53
5		5,04	4,40	4,00
6		5,87	5,38	4,56
7		6,80	6,24	5,19
8			7,11	5,87
9				6,70
10				7,58
11				8,65

21.3 NuVinci gear range

NuVinci hubs have a wider gear range than the Nexus hubs. This means that the NuVinci hub has a shorter low gear and a longer top gear than the Nexus hub. The wider the gear range, the lower the speed at which you can shift into a lower gear and the longer you can keep pedalling at high speed without having to spin the pedals round at high speed. Accordingly, the N380 has a low gear which is twice as low as the lowest gear in the Nexus 3-speed hub. If we compare it with a Nexus 8, the NuVinci hub is able to shift to one gear lower and one gear higher.

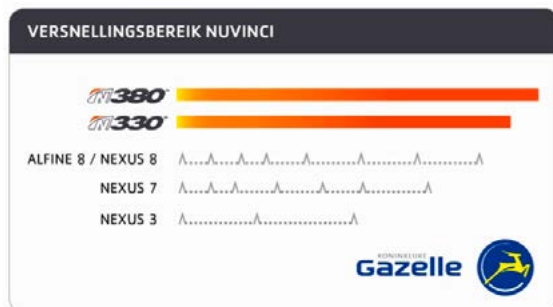

22. Contact details

Do you have any further questions arising from this manual? If so, please contact our Customer Service Centre:

Royal Dutch Gazelle / Koninklijke Gazelle

Wilhelminaweg 8
6951 BP Dieren
The Netherlands

Postal address

Postbus 1
6950 AA Dieren
The Netherlands

T +44 (0) 203 318 2058 (local rate)

I www.gazellebikes.co.uk

Finally

In this booklet, we have set out how you can get pleasure out of your new Gazelle bike for as long as possible and how you can carry out maintenance and any minor repairs yourself. However, do not take unnecessary risks when doing so. If you find any of this somewhat too technical or if you are not confident in your own skills, then go and see your Gazelle specialist. He has all the expertise in his workshop to keep your bike in peak condition.

Disclaimer

Naturally Gazelle has taken great care in compiling this manual. However, liability resulting from printing or typographical errors is excluded.

Royal Dutch Gazelle / Koninklijke Gazelle

Wilhelminaweg 8
6951 BP Dieren
The Netherlands

Postal address

Postbus 1
6950 AA Dieren
The Netherlands

www.gazellebikes.co.uk

GAZ_ALG_EN_191

Ride like the Dutch |

ROYAL DUTCH
Gazelle

